

**KIT PART NUMBER 1720001**  
**INSTRUCTIONS FOR INSTALLING THE posi-vend™ KIT IN A GPL**  
**SNACK MACHINE**

**CHECK THE PARTS RECEIVED IN THE KIT WITH THE PARTS LIST IN THESE INSTRUCTIONS. IF ANY PARTS ARE MISSING, CONTACT THE NATIONAL VENDORS PARTS DEPARTMENT IMMEDIATELY.**

Read these instructions carefully before installing the kit.  
 Keep these instructions for part numbers and for future reference.

**NOTE: IF YOUR MACHINE HAS A REFRIGERATED/FROZEN FOOD MODULE, YOU ALSO NEED KIT 7970004.**

**THIS KIT CONTAINS THE FOLLOWING :**

<b>PART NUMBER</b>	<b>DESCRIPTION</b>	<b>QUANTITY</b>
1451097	SCREW - #8 - 32 X .31 HEX HD TF - BLK	1
1452139	RETAINER - HARNESS	3
1720023	SET UP GUIDE - MAIN - GPL	1
1670035	ALCOHOL WIPES - 1 7/8" X 3 3/8	2
1672029	SENSOR BRACKET - ASSEMBLY - LT	1
1672032	SENSOR BRACKET ASSEMBLY - RT	1
1672038	DEFLECTOR - INNER - RH - FLT "T" BLK	1
1672039	DEFLECTOR - INNER - LH - FLT "T" BLK	1
1672043	COVER - PCB - LH	1
1672044	COVER - PCB - RH	1
1672050	PAPER BACKING - LT. PCB	1
1672051	PAPER BACKING - RT. PCB	1
1672052	LABEL - GUM & MINT - MATTE	1
1672054	FILLER ASSEMBLY - LT - DEL PAN	1
1672055	FILLER - RT - DEL. PAN	1
1672056	PRODUCT DEFLECTOR ASSY - RH (38" CABINET ONLY)	1
1725003	INSERT - INSTR - UPPER - POSI-VEND™ - GPL	1
1726000	PCB ASSEMBLY - PRODUCT DET. - RECEIVER - GPL	1
1726001	PCB ASSEMBLY - PRODUCT DET. - EMITTER - GPL	1
1679012	HARNESS - MAIN CONTROLLER TO SENSOR	1
1679013	HARNESS - EMITTER TO DETECTOR	1
1681058	DEFLECTOR - UPPER LHS - PLASTIC	1
1682054	PRODUCT DEFLECTOR ASSEMBLY - RH (32" CABINET ONLY)	1
2342044	CLIP - CHRISTMAS TREE	2
3101144	SCREW - 1/4 - 20 X 1/2" HEX HEAD W/LOCK WASHER	2
4042121	WIRE TIE - #PLT1M - M20	1
4721035	SCREW - #8-18 X .38	1
4732024	RETAINER - HARNESS	4

---

**THIS KIT CONTAINS THE FOLLOWING (CONTINUED):**

<b>PART NUMBER</b>	<b>DESCRIPTION</b>	<b>QUANTITY</b>
5262216	SCREW - #6 - 32 X 1/4" PPHD M SCR.	10
7841017	OVERLAY - NON-REFLECTIVE - 8 SELECT CAN	1
7852000	COVER - PCB - RH (COFFEE MODULE ONLY)	1
7852001	DEFLECTOR - RT - PLASTIC (COFFEE MODULE ONLY)	1
7971014	OVERLAY NON - REFL UPPER DEFLECTOR	1
7971015	OVERLAY NON - REFL LOWER PILFER DR	1
7972020	LOCK ASSEMBLY - VEND DOOR - POSI-VEND™ (7970004 KIT ONLY)	1
9900081	NUT - # 8 - 32 - KEPS ZINC PLATE	2
9900207	NUT - 10 - 32 SELF LOCKING	1
P1606011	EPROM ASSEMBLY - POSI-VEND	1

---

**Proceed as follows:**

1. Turn the machine power switch OFF and disconnect the machine from electrical source.
2. ***SKIP THIS STEP IF YOU HAVE A MACHINE WITH A COFFEE MODULE.*** Attach plastic deflector 1681058 to the cabinet wall with the christmas tree clips 2342044 as shown (figure 2).
3. Remove and discard all deflectors as shown (figure 3). Thoroughly clean the shaded areas shown with the alcohol wipes provided. After removing all grease and dirt on these parts, apply the black overlays to these areas as described in the illustration. Cut the overlays to length along the clear lines according to the width of your delivery pan.
4. Apply the remaining overlay (without clear lines) to the underside of the 8-can select module only. Position the overlay even with the front edge, and centered side to side (figure 4).
5. According to the model you have, remove any existing filler assemblies or gum and mint module mounting hardware.
6. Remove the screws holding the upper deflector, but leave the part resting in place (figure 3).
7. Loosely attach the left and right sensor bracket assemblies and the new inner deflectors to the delivery pan sides, (figures 5 and 6). **VERY IMPORTANT:** align the lower hole of the bracket as shown to the hole in the side of the delivery pan and tighten the screws on the sides of the delivery pan (figures 5 and 6).
8. Attach the front of each sensor bracket and the upper deflector to the door (figures 5 and 6).
9. Attach the new filler assembly or gum and mint mounting hardware to the delivery pan, (figures 10 through 12). If your machine has a food or can module and no gum and mint module, attach the filler brackets as shown (figure 10). **NOTE:** for the 159, 173, 467 gum and mint module, use the thinner #10 lock nut 9900207 to reattach the module on the bracket side. Remove the old gum and mint label and apply the new label (supplied with this kit) to the same area.
10. If your machine has a coffee module, reassembly the glass retainer to the door (figure 6).
11. ***Plug the machine back into the electrical service (this grounds the machine for the maximum protection against electrostatic discharge).*** Wearing electrostatic discharge protection, attach the left and right sensors assemblies and paper backing to the left and right brackets with the (10) #6 -32 screws provided (figures 5 and 6).
12. ***Skip this step if you have a machine with a coffee module.*** Attach the left and right PCB covers to the brackets (figures 5 and 6). Connect the black emitter to detector harness wire to the two sensor boards (figures 7 and 8).

- 
13. If your machine has a coffee module, attach the left PCB cover and the special right hand PCB cover (figures 5 and 6):
    - a. Slide the right hand PCB cover between the right hand PCB bracket and the glass retainer, and onto the bracket.
    - b. Slide the right plastic deflector between the right hand PCB cover and the glass retainer, and under the front lip of the PCB bracket.
    - c. Attach the assembly to the glass retainer and the bracket as shown.
    - d. Connect the black emitter to detector harness to the two sensors (figures 7 and 8).
  14. Route the wiring along and under the delivery pan with the harness clips as shown (figures 7 and 8). Bundle any excess harnessing under the delivery pan with a wire tie (figure 9).
  15. Connect the gray main controller to sensors harness wire to the main controller board connector J34 (figure 1) and route it inside the cabinet, making sure it is clear of any moving parts. Connect the harness wire to the sensor board as shown (figure 8). Route the harness wire into the harness clips along the delivery pan.
  16. Wearing electro-static discharge protection, carefully remove the current EPROM and replace with the new EPROM per the instructions beginning on the next page.
  17. If you are experiencing clearance problems with posi-vend™ and the can module, add the 3101144 1/4 - 20x1/2" hex head bolts to the underside of the base of the module. Adjust as needed
  18. If your machine has a refrigerated/frozen food module, you must purchase lock kit part number 7970004. Install this kit to the delivery pan as shown (figure 6).

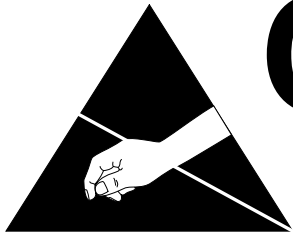

# CAUTION

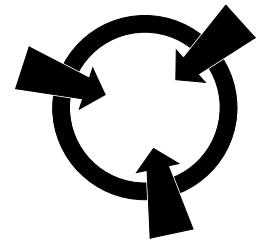

## PREVENTING CIRCUIT DAMAGE FROM ELECTROSTATIC DISCHARGE

Electronic printed circuit board assemblies are susceptible to physical damage, for example, broken components due to rough handling. In addition, printed circuit board assemblies (and their components, such as EPROMs) are subject to damage by various types of static electricity. Damage of this type is called **ELECTROSTATIC DISCHARGE (ESD)**. ESD can cause immediate damage to components on a circuit board assembly, or it can weaken them to the point where the damage will show up days, weeks, or months later.

### PRECAUTIONS TO TAKE WHEN HANDLING PCB ASSEMBLIES

1. The PCB assembly is usually shipped in a cardboard shipping carton to prevent physical damage. Inside the carton, the PCB was placed in 1 of 3 types of closed protective bags: black translucent, smoked gray transparent, or pink transparent.
2. For storage, the best protection for the assembly is to leave it in its shipping carton. If it is removed from the carton, leave the assembly in its **CLOSED storage bag while transporting, or until it is ready to be installed in a machine.**
3. Before handling the PCB assembly, be sure you are wearing a conductive wrist strap or other suitable ESD protective device. The conductive wrist strap should be connected to ground in the machine. This can be any **PLATED exposed metal part. DO NOT CONNECT YOUR WRIST STRAP TO A PAINTED PART.**
4. Remove the new PCB assembly from its bag. Set the PCB assembly on top of the bag on a flat surface while you remove the old PCB assembly from the machine.
5. Pick up the new PCB assembly and set the old one down on the protective bag. Install the new PCB assembly in the machine.
6. Insert the old PCB assembly into the protective bag. Seal the bag.
7. If the old PCB assembly is to be returned to National Vendors, it is best to ship it in the same shipping carton you received with the new PCB assembly.

---

**CAUTION**

*Do not remove the new EPROM from its shipping carton until you are ready to use it.*

**CAUTION**

*Observe electrostatic discharge precautions to protect the electronics from damage while they are being handled. Wear a grounded wrist strap connected to any unpainted metal part of the machine. If a wrist strap is not available, remove any electrostatic charge (static electricity) from yourself by touching any unpainted metal part of the machine before handling any electronic component. Do this often during the removal and installation process.*

- a. On figure 1, see the shaded area representing EPROM U4. These devices have various means of showing how they are to be oriented on the circuit board. Some EPROMs will have a small notch which matches the notch printed on the controller board. Other EPROMs may have a small dimple as shown, others may have a painted stripe. Take note of where the locating mark is on the EPROM currently mounted on the controller board. Your new EPROM will be placed in that same orientation. Some EPROMs have 28 pins, so it does not use the entire socket. The shaded area on the figure is where the new EPROM will go, leaving the four holes at the bottom of the socket empty.
- b. Carefully remove the old EPROM from the controller board. Use an EPROM removal tool or a thin tool such as a small screwdriver or knife blade to gently rock the EPROM from its socket.
- c. Carefully insert the new EPROM in the controller board. **MAKE SURE THE LOCATING MARK (NOTCH, DIMPLE, STRIPE) ON THE EPROM IS FACING THE SAME WAY AS ON THE OLD EPROM!** Make sure each of the pins is in its respective hole in the socket before pushing the EPROM into place.
- d. Carefully seat the EPROM into place using uniform pressure all around.

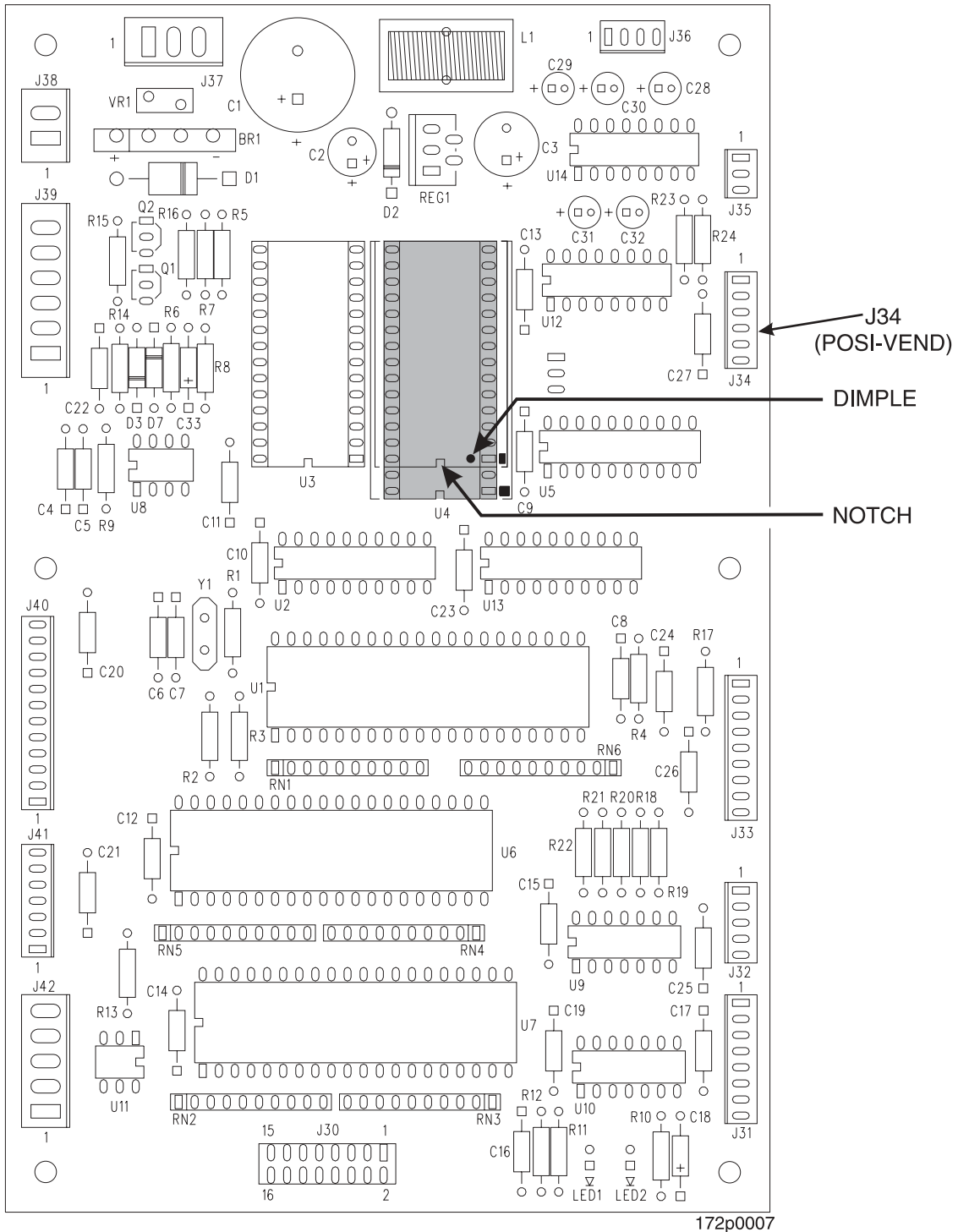

**Figure 1. Controller Card Showing the Location of EPROM U4**

- e. Replace all items you removed.
  - f. Turn the machine power ON.
19. Power up the machine. You are now ready to check the sensors in the diagnostics mode (refer to the *Programming Guide*).

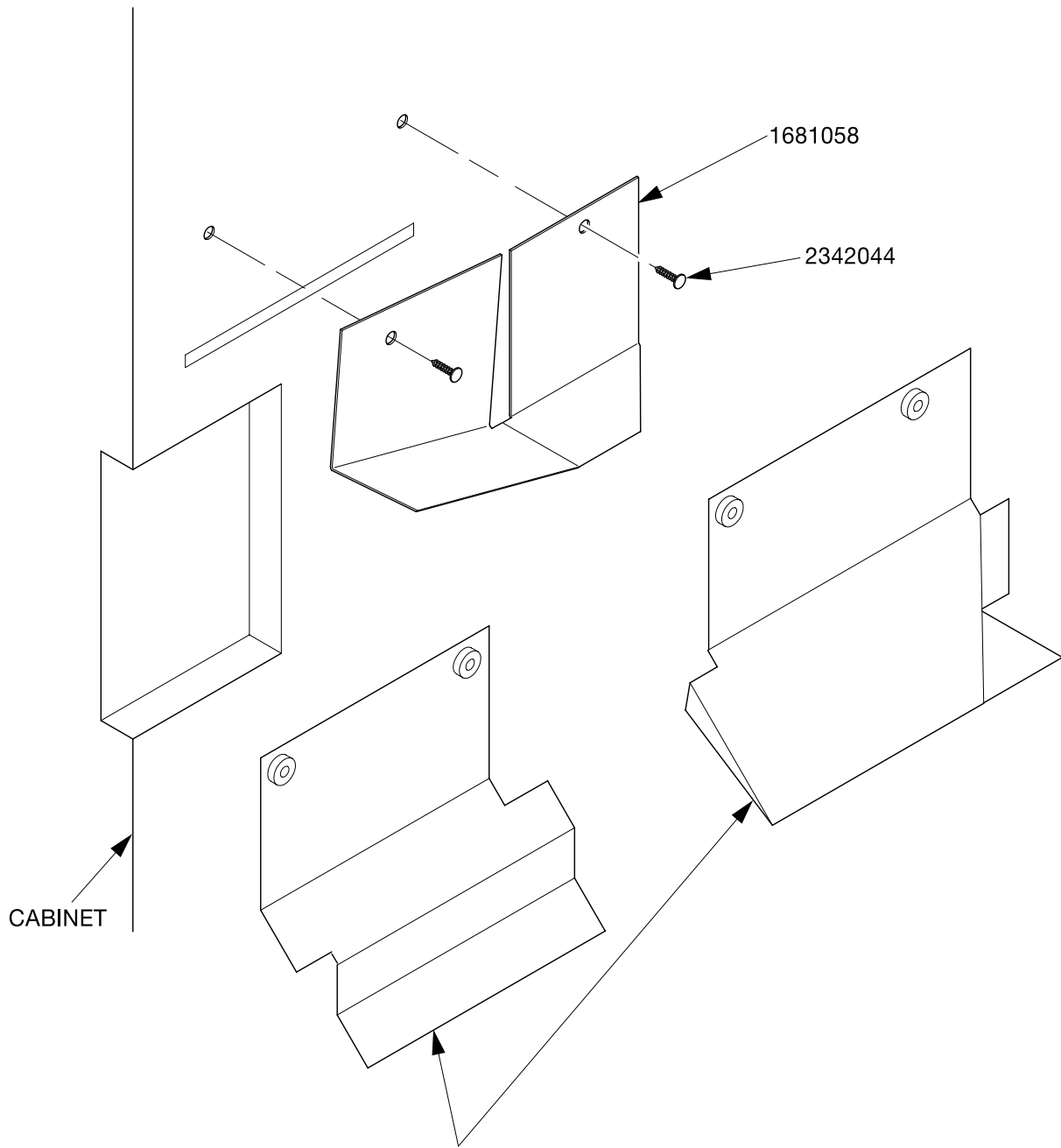

CABINET

1681058

2342044

REMOVE AND DISCARD  
 DEFLECTOR STYLE THAT  
 IS ON MACHINE FROM  
 SIDE OF CABINET AND  
 REPLACE WITH 1681058

167pk019

Figure 2



**IMPORTANT: DO NOT APPLY OVERLAYS TO DELIVERY PAN AREAS WHICH HAVE ALREADY BEEN PAINTED WITH TEXTURED PAINT.**

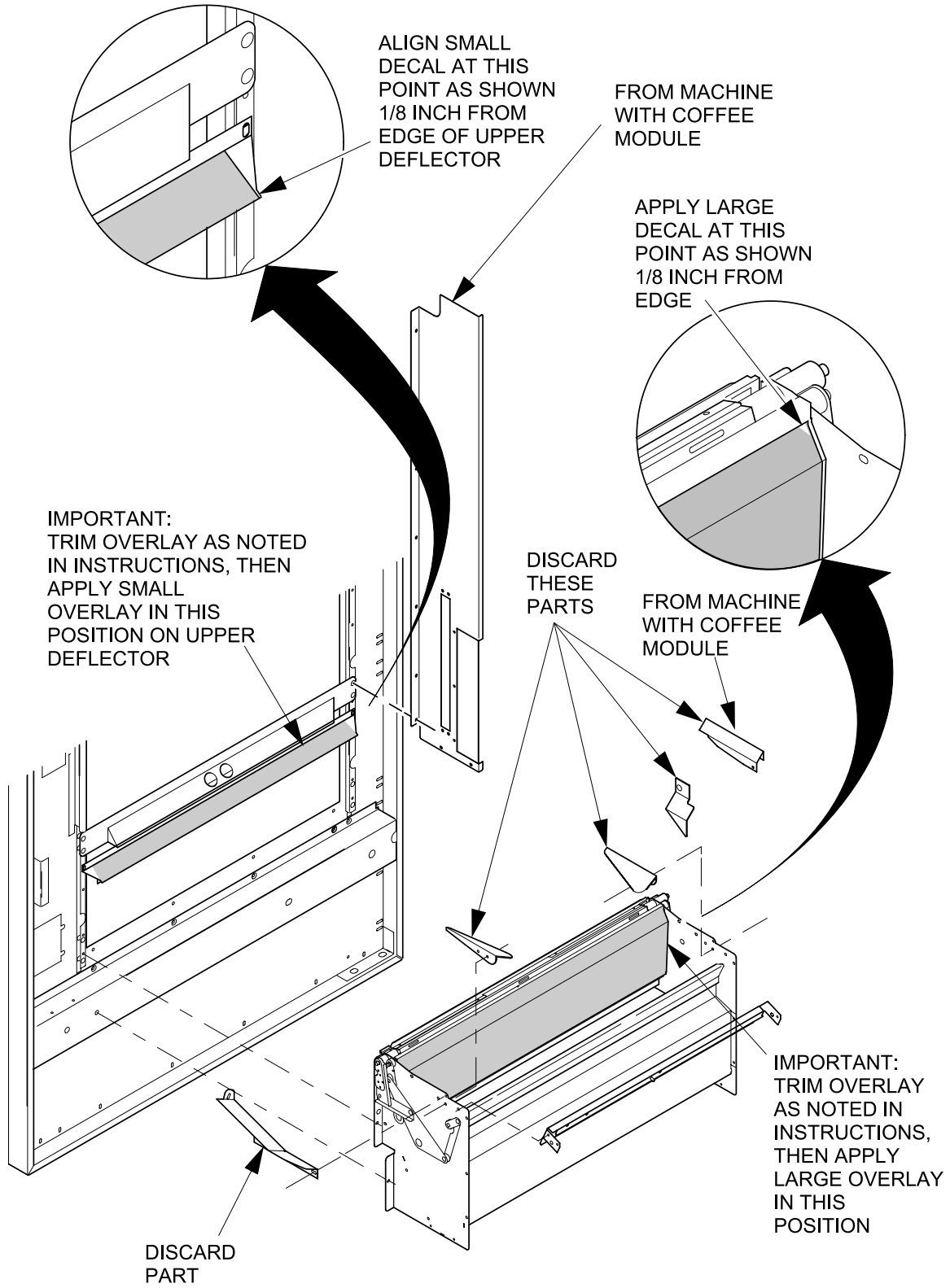

DELIVERY PAN SHOWN REMOVED FOR CLARITY ONLY

167pk030

**Figure 3**

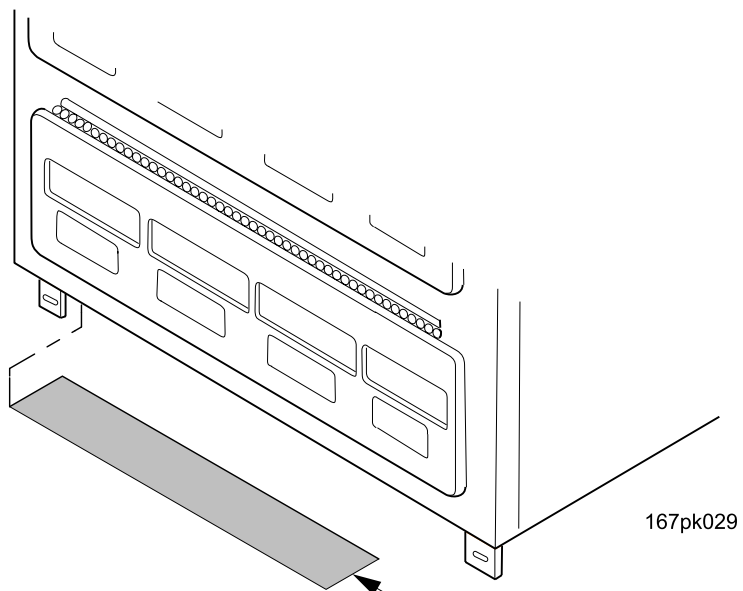

ADHERE OVERLAY UNDER  
THE 8 SELECT CAN MODULE ONLY.  
ALIGN WITH FRONT EDGE  
AND CENTER OVERLAY.

**Figure 4**

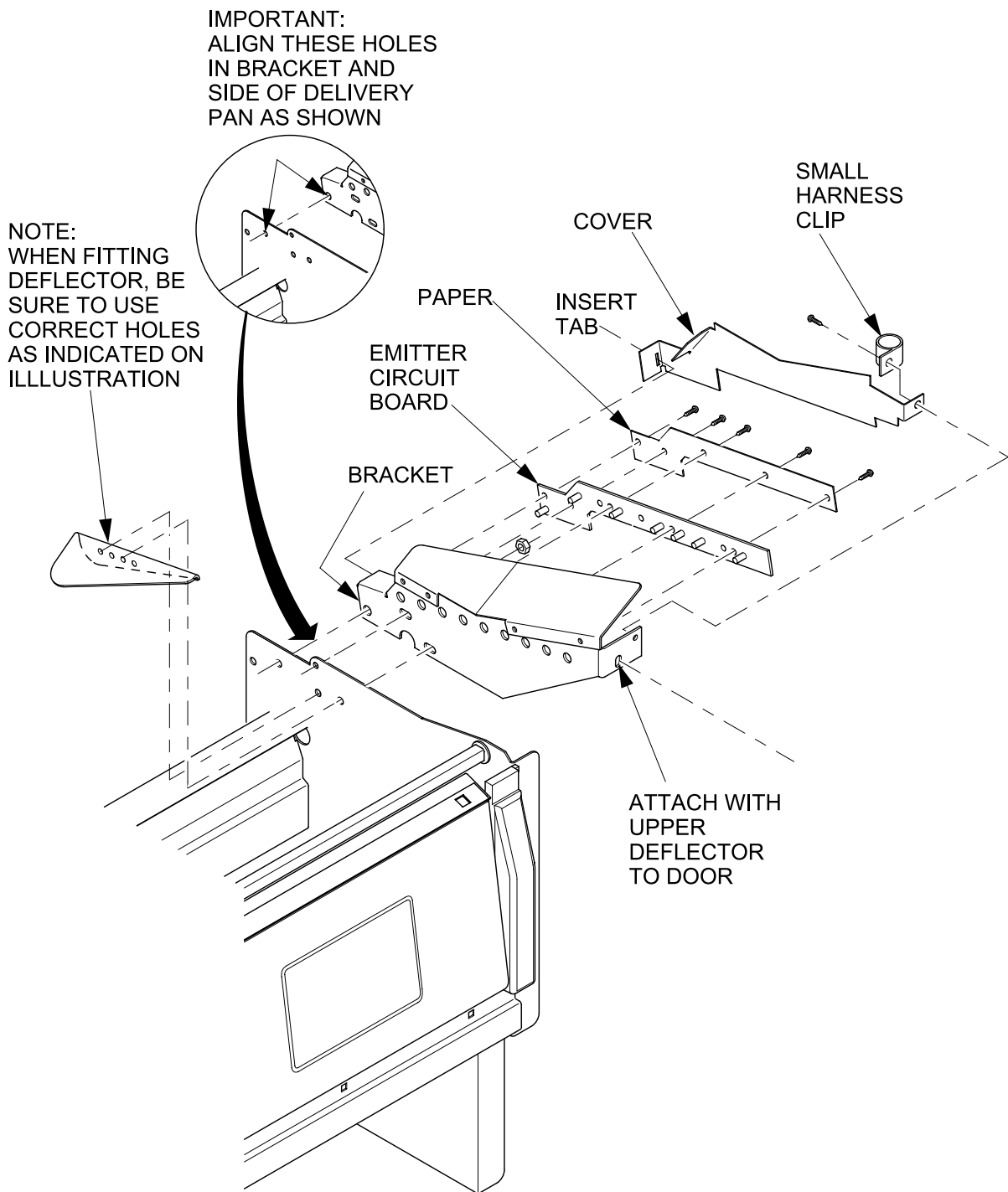

172pk007

LOCK SIDE OF DOOR

Figure 5

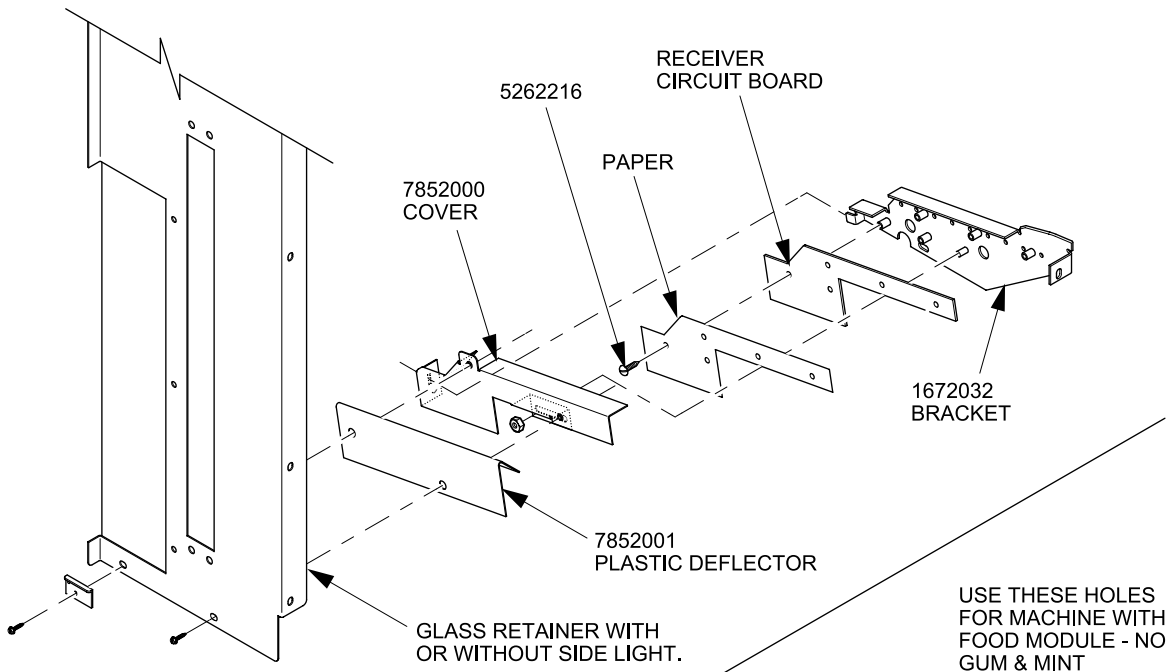

MACHINE WITH COFFEE MODULE

USE THESE HOLES FOR MACHINE WITH FOOD MODULE - NO GUM & MINT

NOTE:  
WHEN FITTING DEFLECTOR, BE SURE TO USE CORRECT HOLES AS INDICATED ON ILLUSTRATION

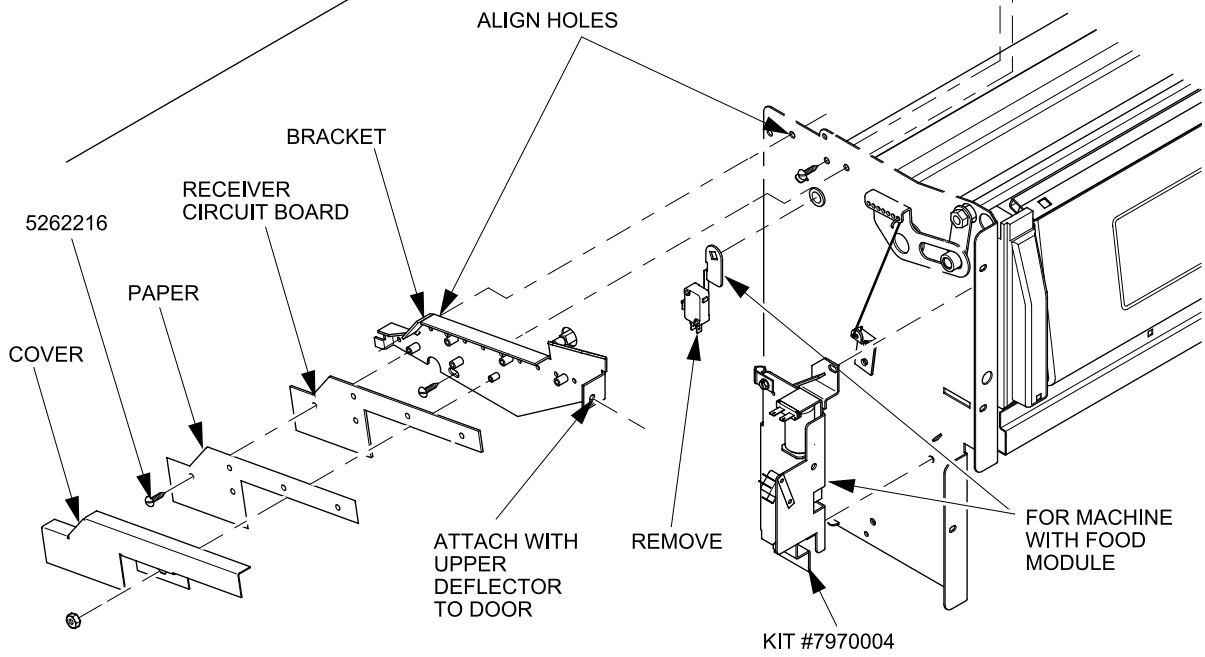

HINGE SIDE OF DOOR

167pk031

Figure 6

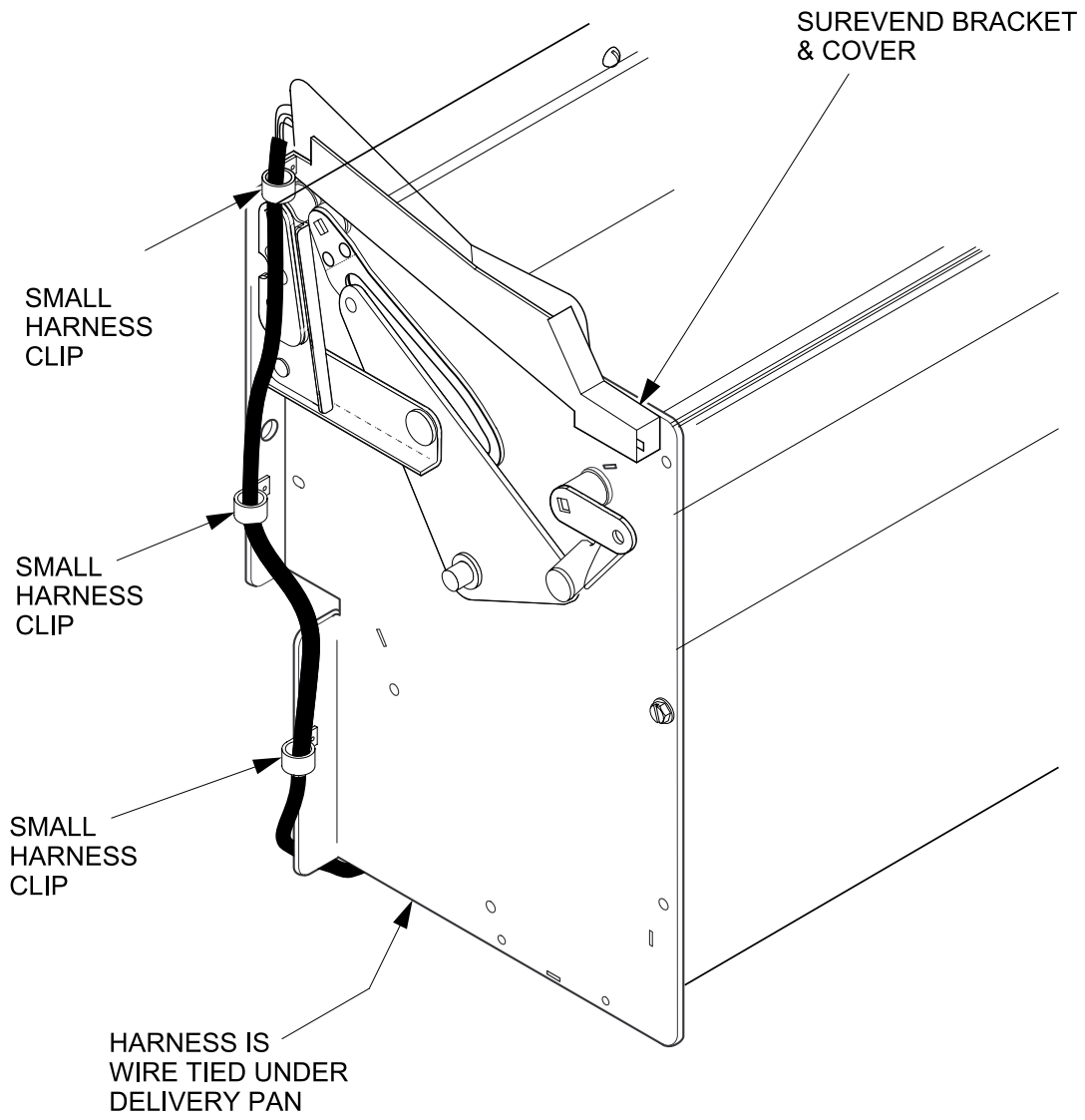

LOCK SIDE VIEWED FROM THE INTERIOR OF DOOR

167pk023

Figure 7

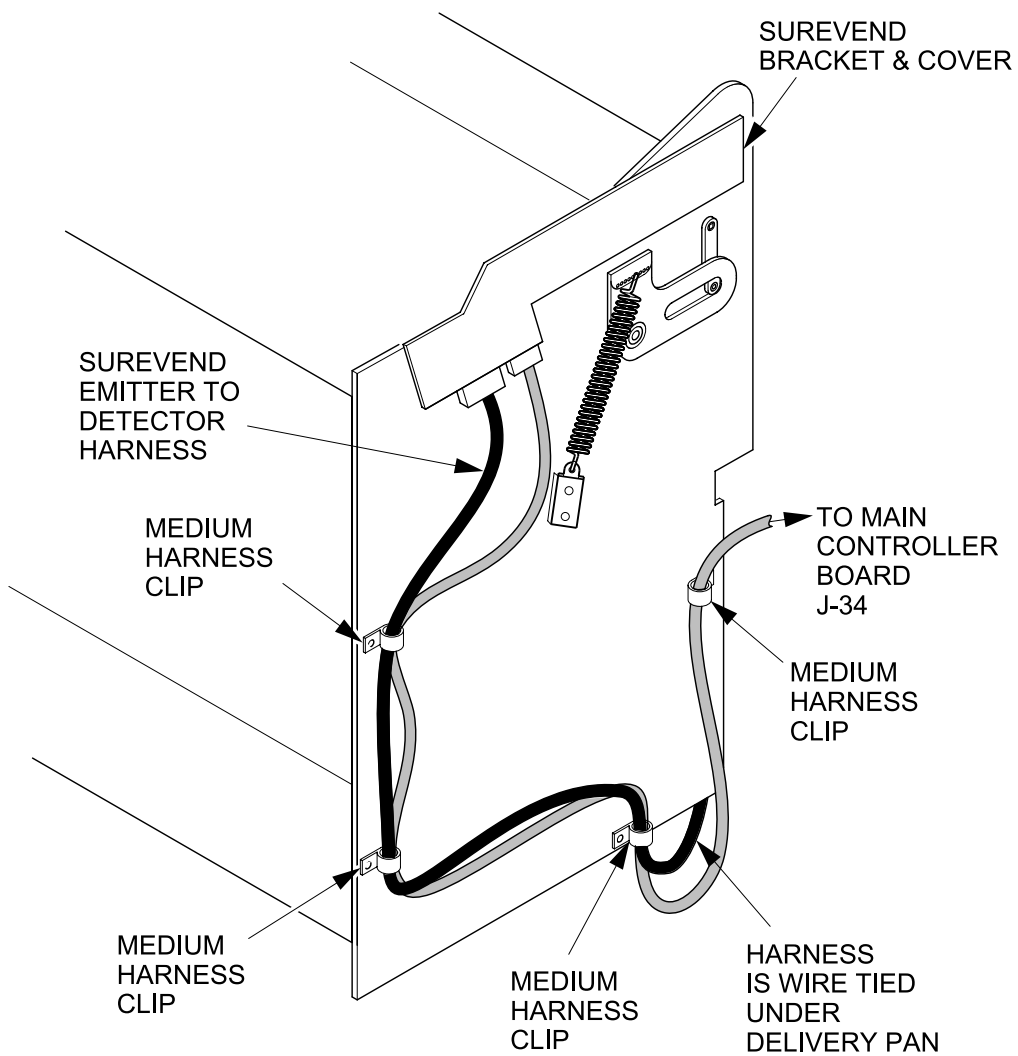

HINGE SIDE OF DELIVERY PAN  
VIEWED FROM THE INTERIOR  
OF DOOR

167pk024

Figure 8

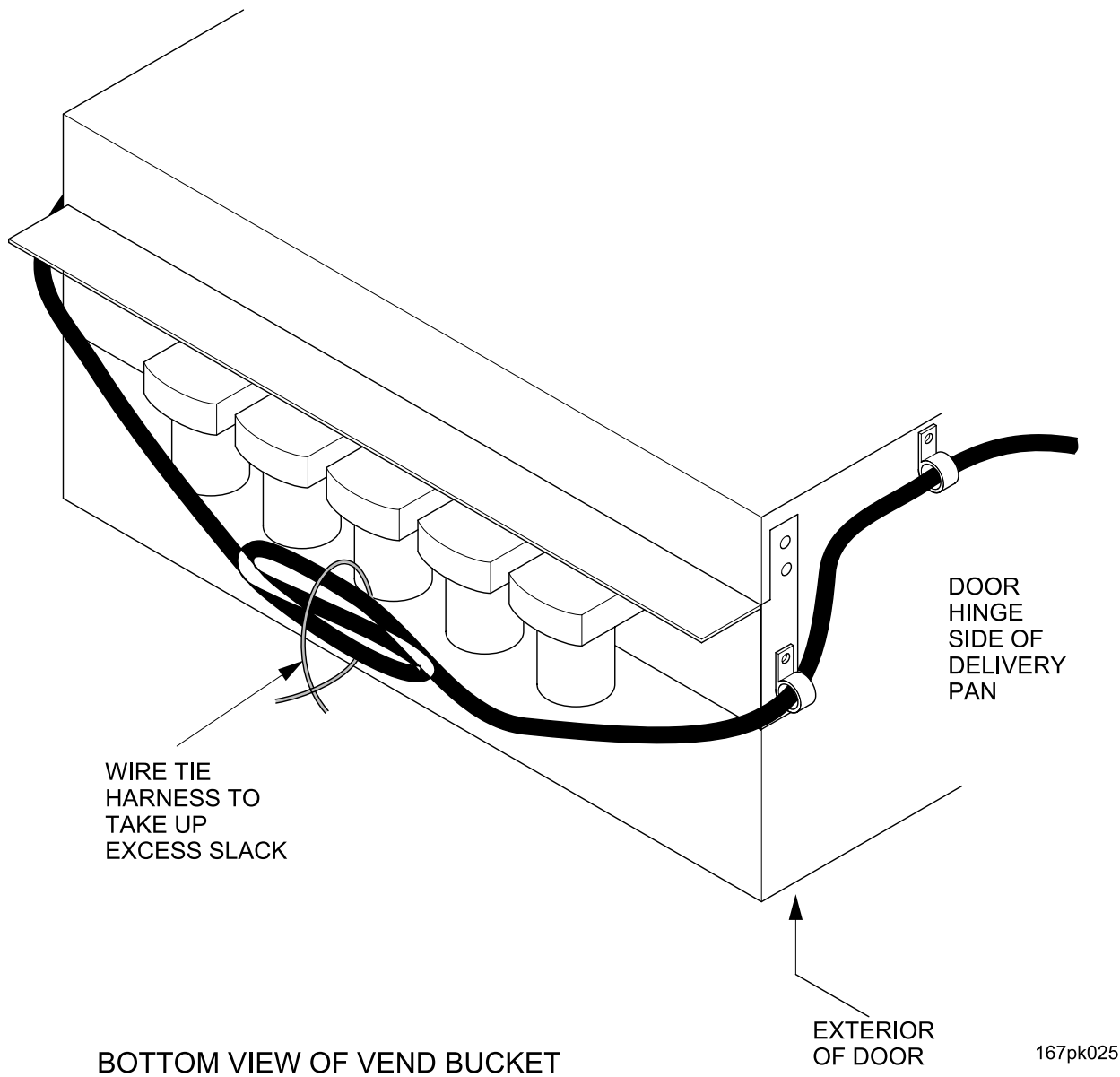

**Figure 9**

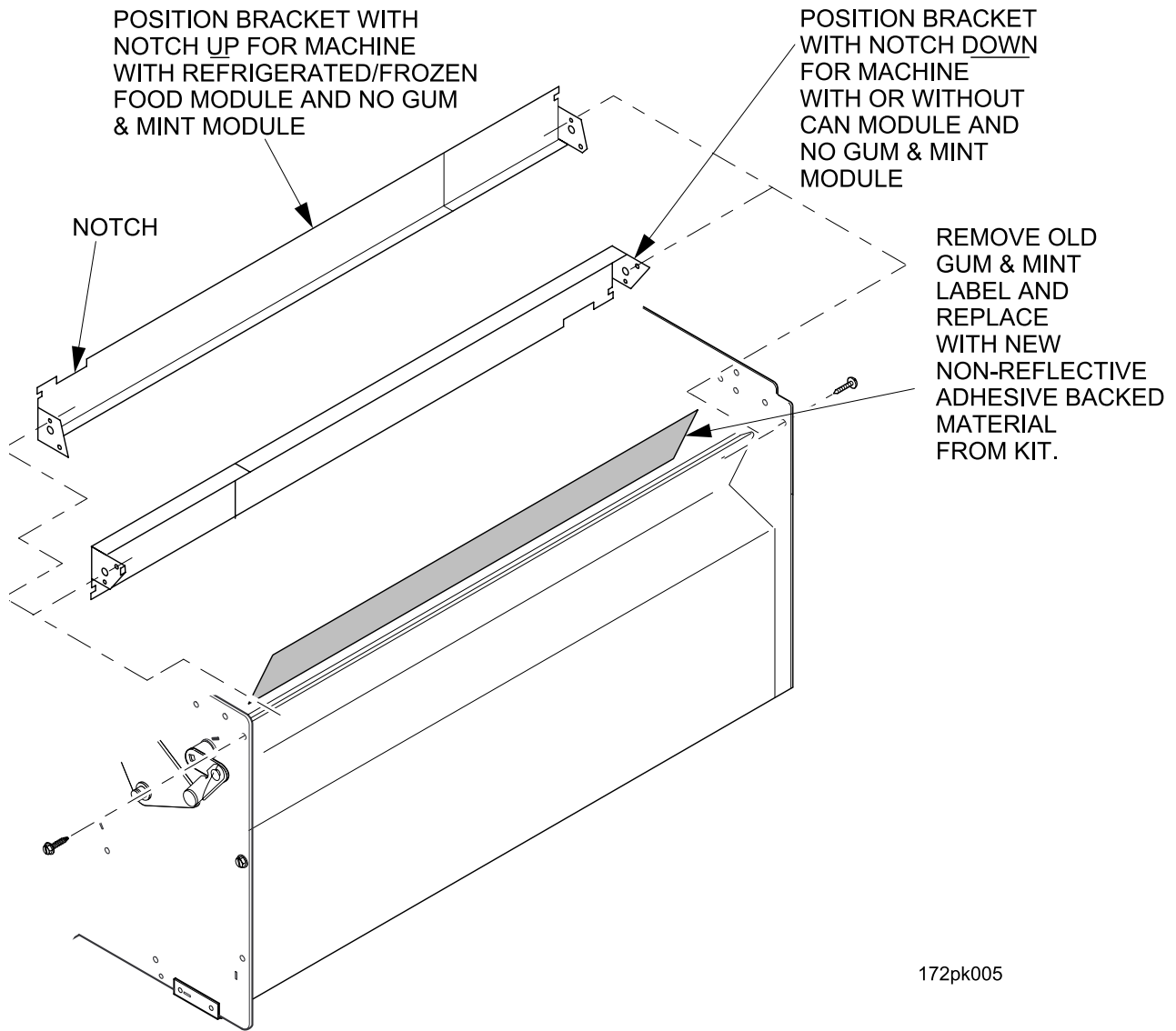

Figure 10



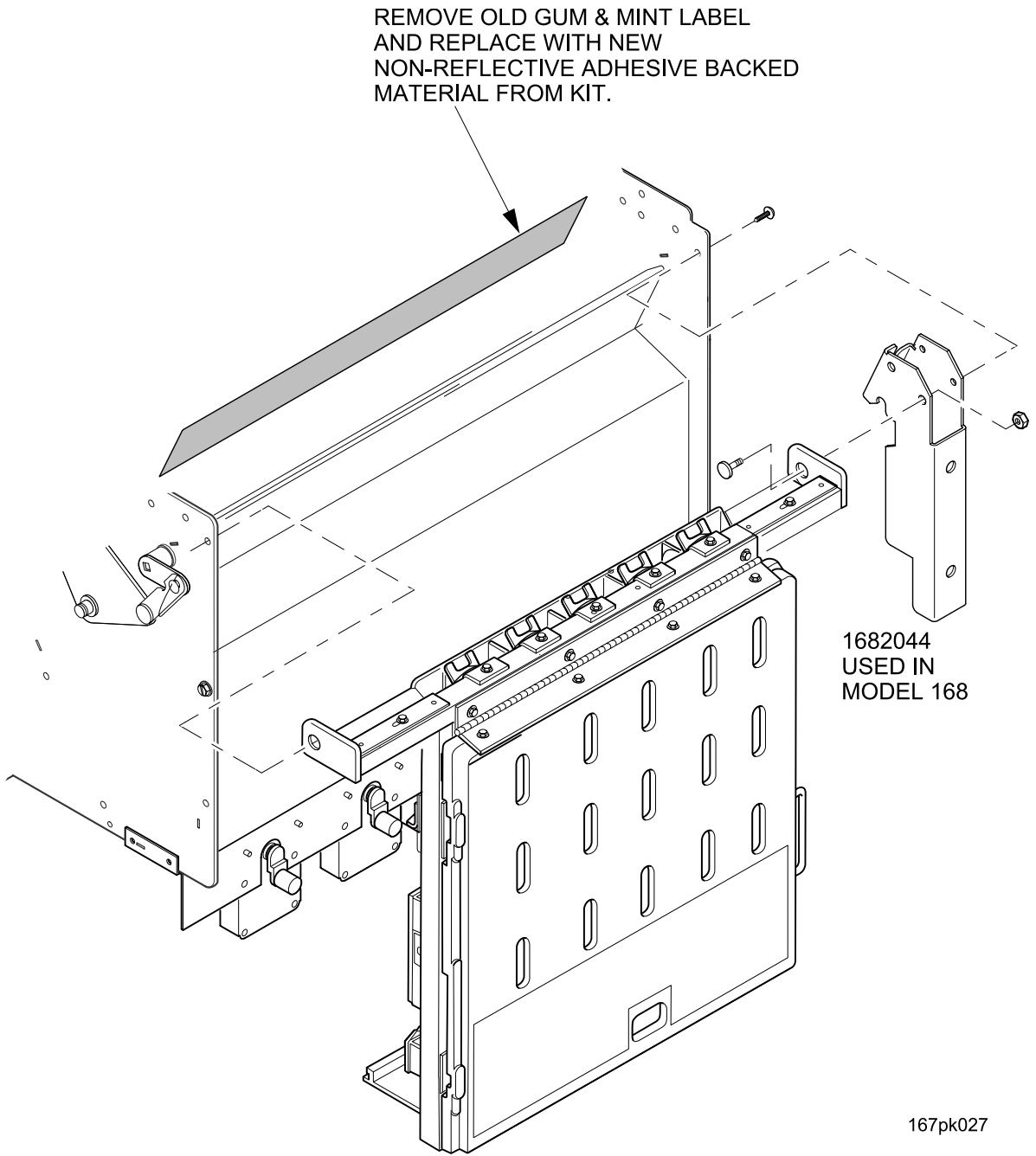

Figure 11

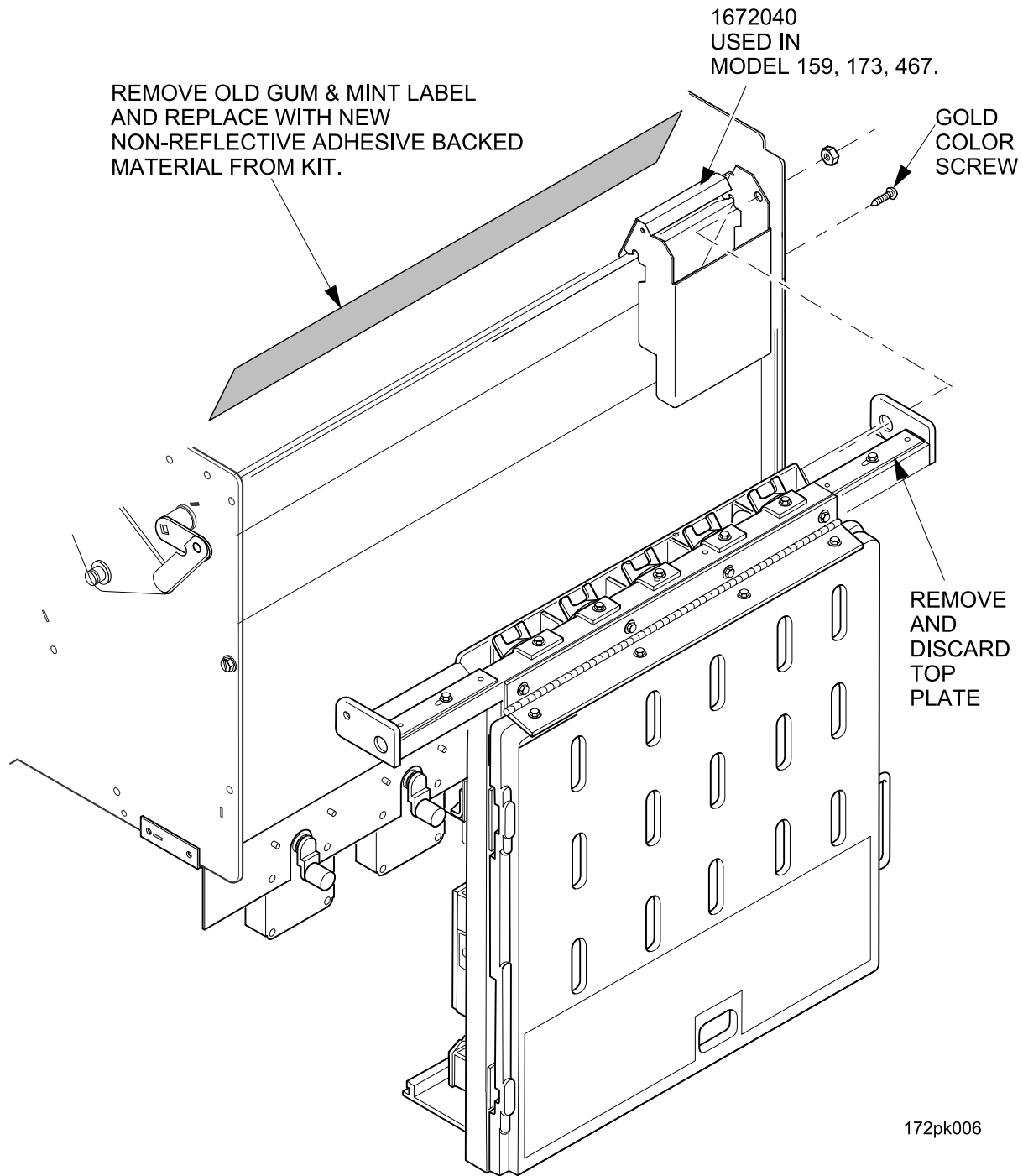

Figure 12